

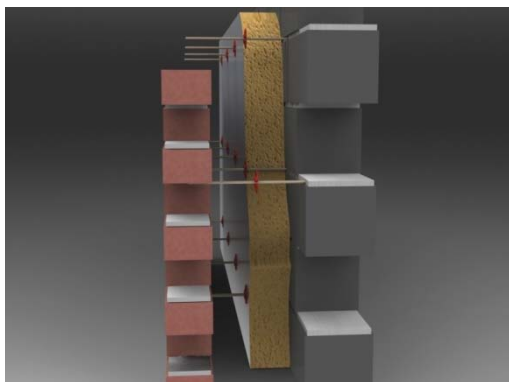

QWIK-FIX™ GFRP WALL TIES

PRODUCT SPECIFICATION SHEET



1. TECHNICAL SPECIFICATION

1.1 DESCRIPTION

Qwik-Fix™ GFRP Wall Ties are thermally insulating, symmetrical, horizontal composite wall ties. They comprise pultruded glass fibres which are set into a matrix of vinyl ester resin. The ties have a coarse silica finish to help ensure a good bond with the mortar joint and to help prevent moisture crossing the cavity. The ties are available in the sizes given in Tables 1 and 2 below for use in cavity widths ranging from 50mm to 200mm. The ties are nominally 4.8mm thick including the silica coating (3mm without), 16mm wide, and they have a chevron-shaped profile.

Table 1: Assuming a 100mm Inner Leaf

| Tie Type | Cavity Range | Recommended Length | Max Storey Height | Product Code |
|----------|--------------|--------------------|-------------------|--------------|
| 2 | 70-120mm | 250mm | 15 | QF-WT-T2-250 |
| 2 | 120-145mm | 275mm | 15 | QF-WT-T2-275 |
| 2 | 150-200mm | 325mm | 15 | QF-WT-T2-325 |

Table 2: Assuming a 215mm Inner Leaf

| Tie Type | Cavity Range | Recommended Length | Max Storey Height | Product Code |
|----------|--------------|--------------------|-------------------|--------------|
| 2 | 50-120mm | 250mm | 15 | QF-WT-T2-250 |
| 2 | 125-200mm | 325mm | 15 | QF-WT-T2-325 |

1.1 [a] IMPORTANT NOTES ON SECTION 1.1

- [a] Tie type classification as defined in BS 5628-1 : 2005 and Eurocode 6
- [b] Care should be taken to ensure that the mortar joints are correctly aligned to ensure that the ties adequately fit into each leaf with a slight fall towards the outer leaf. Individual leaves may be coursed concurrently or separately
- [c] In accordance with EN 845-1 : 2003, the declared minimum mortar joint thickness is 10mm.

1.2 QUALITY CONTROL

Quality control of the ties includes checks on incoming materials and regular visual and dimensional checks during and post manufacture, in line with CE Marking guidelines in relation to EN 845-1.

1.3 DELIVERY & SITE HANDLING

Qwik-Fix™ GFRP Wall Ties are delivered in bags of 100 ties. Care should be taken to avoid long term storage of the wall ties in areas of the site which are typically exposed to direct sunlight.

2. ASSESSMENT & TECHNICAL INVESTIGATIONS

2.1 GENERAL DESIGN CONSIDERATIONS

- 2.1 [a] The ties are suitable for use in new masonry walls with the heights and cavity widths given in Tables 1 & 2
- 2.1 [b] The ties must be used in accordance with Eurocode 6 and BS 5628-3 : 2005
- 2.1 [c] The silica coating of the ties acts as an effective drip to prevent water transfer across the cavity. The ties should be installed to allow a slight fall from inner leaf to outer leaf, to further prevent water transfer across the cavity.
- 2.1 [d] It is not normal practice for the ties to be installed across cavities less than 50mm wide. Where this does occur, it is important to ensure that requirements relating to weather tightness are met.
- 2.1 [e] Ties should be used at a minimum density of 2.5 per square metre (900mm horizontal by 450mm vertical centres). For ordering purposes, budget for at least 3 ties per square metre.
- 2.1 [f] Ties should be evenly distributed over the wall area and should preferably be staggered
- 2.1 [g] At the vertical edges of an opening, unreturned or un-bonded edges, and at vertical expansion joints, ties should be used at 300mm vertical centres, located not more than 225mm from the edge.

2.2 PRACTICABILITY OF INSTALLATION

The ties are designed to be installed by a competent general builder, or a contractor, experienced with this type of product. They can be built easily into brickwork or block work during construction.

2.3 STRUCTURAL PERFORMANCE

2.3 [a] According to tests carried out generally in accordance with EN 845-1 : 2003, Qwik-Fix™ GFRP Type 2 Wall Ties are suitable for use in Light Duty and General Purpose applications.

2.3 [b] In testing generally in accordance with EN 846-5 [Methods of Test for Ancillary Components for Masonry : Part 5 - Determination of Tensile and Compressive Load Capacity and Load Displacement Characteristics of Wall Ties (Couplet Test)], failure in tension was determined by pull out from the masonry; in compression by buckling.

2.3 [c] The following are the manufacturer's declared values at Ultimate Load (N), assuming a worst case scenario, i.e. a 325mm long wall tie, used in a 200mm wide cavity:

| | Manufacturer's Declared Value | EN 845-1 Min. Required Value |
|-------------|-------------------------------|------------------------------|
| Tension | 3900 | 1800 |
| Compression | 1850 | 1300 |

2.4 BEHAVIOUR IN RELATION TO FIRE

The effectiveness of the installed ties in fire is assessed as being equivalent to that of typical steel ties. Guidance on the fire resistance of cavity walls is given in BS 5628-3 : 2001 and Eurocode 6.

2.5 THERMAL PERFORMANCE

The U-Value of a completed wall will depend on the selected insulation thickness, the insulating value of the substrate masonry and its internal finish. Calculations of thermal transmittance (U-Value), including corrections for wall ties (if required), should be carried out in accordance with EN ISO 6946 : 2007, using a thermal conductivity of 0.19 W/m.K for the wall ties.

2.6 CONDENSATION RISK & WEATHER TIGHTNESS

Walls should be designed to limit the risk of interstitial and surface condensation. Guidance may be obtained from BS 5250 : 2002 and BRE report (BR 262 : 2002) *Thermal insulation : avoiding risks*

The water shedding detail of the Qwik-Fix™ GFRP Wall Ties is effective in preventing the transfer of water across the ties to the inner leaf. The chevron profiled wall ties should be installed so that the "hump" in the middle is pointing upwards

2.7 MAINTENANCE & DURABILITY

The ties are resistant to corrosion and are contained within the cavity. Therefore, they require no maintenance. Prolonged exposure of the ties to direct sunlight should be avoided, if possible. The ties will not be adversely affected by mortar (including those incorporating conventional mortar admixtures) or cavity insulation materials. The ties should have a service life of not less than 60 years.

3. INSTALLATION

3.1 GENERAL

Qwik-Fix™ GFRP Wall Ties should be installed in accordance with the requirements of BS 5628-3 : 2005, Eurocode 6 and as per the instructions detailed in this document.

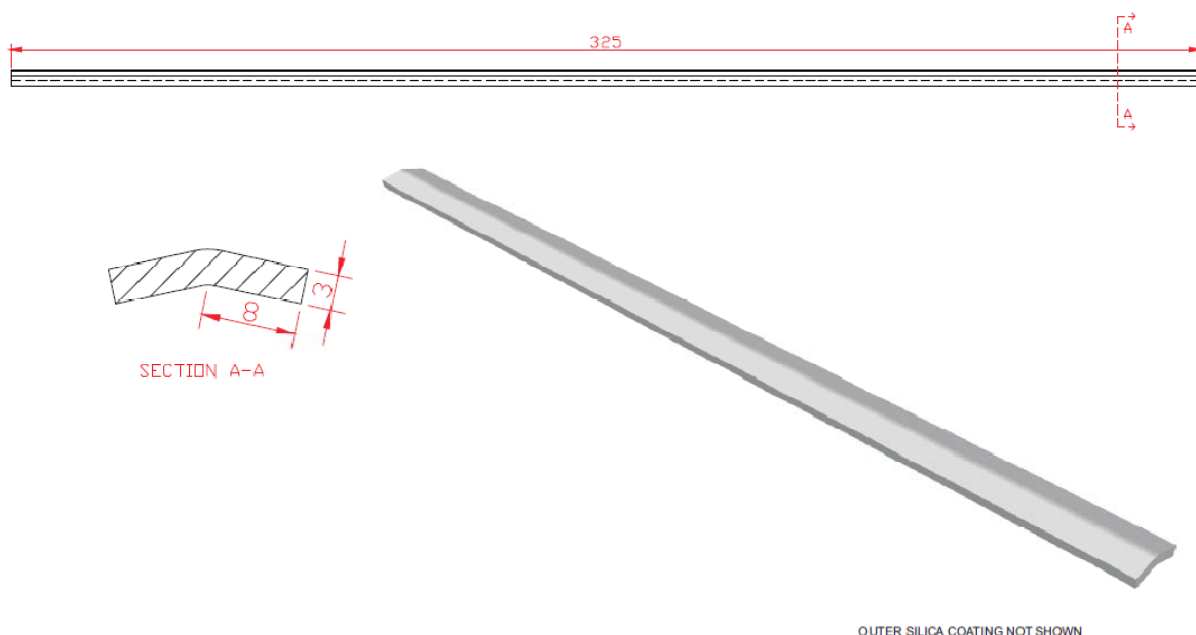

3.2 PROCEDURE

Qwik-Fix™ GFRP Wall Ties should be sandwiched between mortar in joints of 10mm design thickness, ensuring the ties are fully covered. The minimum embedment length is 50mm but the *design* embedment length is 62.5mm. The middle of the chevron-profiled wall tie should be installed pointing upwards, as illustrated above. The wall ties are symmetrical at either end and should be installed substantially horizontally, at right angles to the wall, allowing for a slight fall from inner leaf to outer leaf. The coarse silica coating acts as an effective moisture drip.

In partially filled cavities, insulation should be notched to fit closely around the ties. Insulation clips must be pushed up against the insulation to hold it securely against the inner leaf. Care should be taken to minimise the amount of mortar dropped into the cavity. The first run of ties should be laid one course above the damp-proof course. Other queries should be directed to info@qwikfixings.com